

EDH12TRBD2
EDH14TRBD2

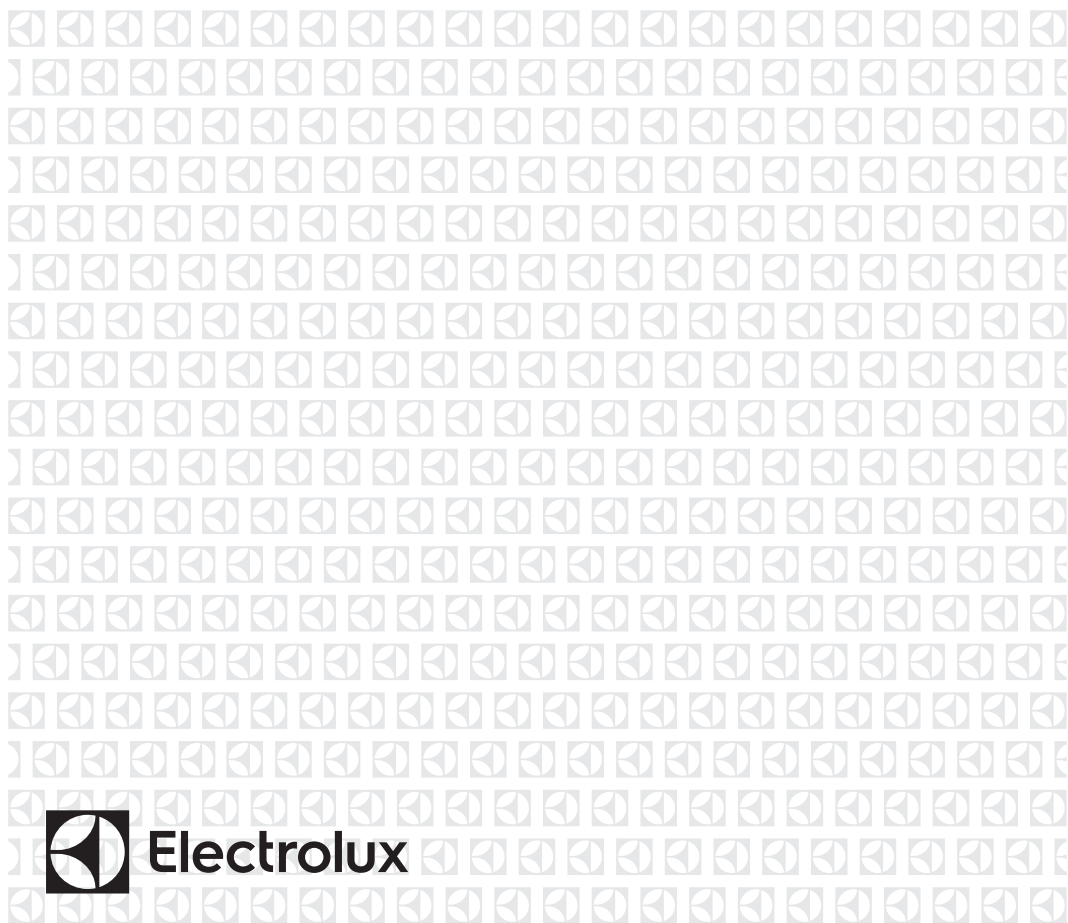

CONTENTS

1. SAFETY INFORMATION.....	3
2. PRODUCT DESCRIPTION	21
3. BEFORE FIRST USE	23
4. OPERATING INSTRUCTIONS	24
5. CARE, CLEANING AND STORAGE.....	31
6. WHAT TO DO IF... ..	33
7. ENVIRONMENT CONCERNS.....	35

WE'RE THINKING OF YOU

Thank you for purchasing an Electrolux appliance. You've chosen a product that brings with it decades of professional experience and innovation. Ingenious and stylish, it has been designed with you in mind. So whenever you use it, you can be safe in the knowledge that you'll get great results every time.

Welcome to Electrolux.

Visit our website to:



Get usage advice, brochures, trouble shooter, service information:
www.electrolux.com



Register your product for better service:
www.registerelectrolux.com



Buy Accessories, Consumables and Original spare parts for your appliance:
www.electrolux.com/shop

CUSTOMER CARE AND SERVICE

Always use original spare parts.

When contacting our Authorised Service Centre, ensure that you have the following data available: Model, PNC, Serial Number, the information can be found on the rating plate.

Symbols in the instruction:

 Warning / Caution-Safety information.

 General information and tips.

 Environmental information.





Subject to change without notice.



Caution, risk of fire



1. SAFETY INFORMATION

Symbol	Note	Explanation
	WARNING	This symbol shows that this appliance uses a flammable refrigerant. If the refrigerant is leaked and exposed to an external ignition source, there is a risk of fire.
	CAUTION	This symbol shows that the user manual should be read carefully.
	CAUTION	This symbol shows that a service personnel should be handling this equipment with reference to the installation manual.
	CAUTION	This symbol shows that information is available such as the user manual or installation manual.

Before the installation and use of the appliance, carefully read the supplied instructions. The manufacturer is not responsible for any injuries or damage that are the result of incorrect installation or usage. Always keep the instructions in a safe and accessible location for future reference.

- This appliance is intended to be used in household (indoors) and similar applications.
- This appliance is not intended for use by persons (including children) with reduced physical, sensory or mental capabilities, or lack of experience and knowledge, unless they have been given supervision or instruction concerning use of the appliance by a person responsible for their safety.
- Children should be supervised to ensure that they do not play with the appliance.
- Keep all packaging away from children and dispose of it properly.
- Cleaning and user maintenance shall not be made by children without supervision.

- Unplug the appliance before moving or carrying out any maintenance.
- If the supply cord is damaged, it must be replaced by the manufacturer, its service agent or similarly qualified persons in order to avoid a hazard.
- The appliance shall be installed in accordance with local wiring regulations.
- **WARNING:** Do not use mechanical devices or other means to accelerate the defrosting process, other than those recommended by the manufacturer.
- Do not use or store the appliance in a room with operating ignition sources, such as open flames, operating gas appliances or electric heaters.
- Do not use harsh abrasive cleaners or sharp metal scrapers to clean the appliance to avoid damaging the surface or water leakage.
- Use only accessories, parts or tools recommended for this appliance.
- The fuse is 250V, 3.15A.

PLEASE NOTE: CHECK THE PLATE FOR THE TYPE OF REFRIGERANT GAS USED IN YOUR APPLIANCE.



WARNING!

Specific information regarding appliances with R290 refrigerant gas.

- Thoroughly read all of the warnings.
- When defrosting and cleaning the appliance, do not use any tools other than those recommended by the manufacturing company.
- The appliance shall be stored in a room without continuously operating ignition sources (for example: open flames, an operating gas appliance or an operating electric heater.)

- Do not pierce or burn.
- Refrigerant gases can be odourless.
- This appliance contains a certain number of grams (see rating label back of unit) of R290 refrigerant gas.
- R290 is a refrigerant gas that complies with the European directives on the environment. Do not puncture any part of the refrigerant circuit.
- If the appliance is installed, operated or stored in a non ventilated area, the room must be designed to prevent the accumulation of refrigerant leaks resulting in a risk of fire or explosion due to ignition of the refrigerant caused by electric heaters, stoves or other sources of ignition.
- The appliance must be stored in such a way as to prevent mechanical failure.
- Individuals who operate or work on the refrigerant circuit must have the appropriate certification issued by an accredited organisation that ensures competence in handling refrigerants according to a specific evaluation recognized by associations in the industry.
- The appliance shall be stored in a well-ventilated area where the room size corresponds to the room area as specified for operation.
- Repairs must be performed based on the recommendations from the manufacturing company. Maintenance and repairs that require the assistance of other qualified personnel must be performed under the supervision of an individual specified in the use of flammable refrigerants.
- Do not use a bad or unsuitable socket.
- Do not use machines in the following situations
 - a) Near to source of fire.
 - b) An area where oil is likely to splash.

- c) An area exposed to direct sunlight.
- d) An area where water is likely to splash.
- e) Near a bath, a shower or a swimming pool.

- Never insert your fingers, rods into the air outlet. Take special care to warn children of these dangers.
- Keep the unit upward while transport and storage, for the compressor locates properly.
- Before cleaning the appliance, always turn off or disconnect the power supply.
- When moving the appliance, always turn off and disconnect the power supply, and move it slowly.
- To avoid the possibility of fire disaster, the appliance shall not be covered.
- All the appliance sockets must comply with the local electric safety requirements. If necessary, please check it for the requirements.
- Children should be supervised to ensure that they do not play with the appliance.
- This appliance is not intended for use by persons (including children) with reduced physical, sensory, or mental capacities, or lack of experience and knowledge, unless they have been given supervision or instruction concerning use of the appliance by a person responsible for their safety.
- If the supply cord is damaged, it must be replaced by the manufacturer, its service agent or similarly qualified persons in order to avoid a hazard.
- Cleaning and user maintenance shall not be made by children without supervision.
- The appliance shall be installed in accordance with national wiring regulations.

- Contact authorized service technician for repair or maintenance of this unit.
- Do not pull , deform . or modify the power supply cord , or immerse it in water . Pulling or misuse of the power supply cord can result in damage to the unit and cause electrical shock.
- Compliance with national gas regulations shall be observed.
- Keep ventilation openings clear of obstruction.
- Any person who is involved with working on or breaking into a refrigerant circuit should hold a current valid certificate from an industry-accredited assessment authority, which authorizes their competence to handle refrigerants safely in accordance with an industry recognized assessment specification.
- Servicing shall only be performed as recommended by the equipment manufacturer . Maintenance and repair requiring the assistance of other skilled personnel shall be carried out under the supervision of the person competent in the use of flammable refrigerants.
- Do not operate or stop the unit by inserting or pulling out Die power plug, it may cause electric shock or fire due to heat generation .
- Unplug the unit if strange sounds, smell, or smoke comes from it.

NOTE:

- If any parts damage, please contact the dealer or a designated repair shop;
- In case of any damage, please turn off the air switch, disconnect the power supply, and contact the dealer or a designated repair shop;
- In any case, the power cord shall be firmly grounded.
- To avoid the possibility of danger, if power cord is

damaged, please turn off the air switch and disconnect the power supply. It must be replaced from the dealer or a designated repair shop.

General instructions for repairing appliances containing R290.

- Checks to the area. Prior to beginning work on systems containing flammable refrigerants, safety checks are necessary to ensure that the risk of ignition is minimised. For repair to the refrigerating system, the following precautions shall be complied with prior to conducting work on the system.
- Work procedure. Work shall be undertaken under a controlled procedure so as to minimise the risk of a flammable gas or vapour being present while the work is being performed.
- General work area. All maintenance staff and others working in the local area shall be instructed on the nature of work being carried out. Work in confined spaces shall be avoided. The area around the workspace shall be sectioned off. Ensure that the conditions within the area have been made safe by control of flammable material.
- Checking for presence of refrigerant. The area shall be checked with an appropriate refrigerant detector prior to and during work, to ensure the technician is aware of potentially flammable atmospheres. Ensure that the leak detection equipment being used is suitable for use with flammable refrigerants, i.e. nonsparking, adequately sealed or intrinsically safe.
- Presence of fire extinguisher. If any hot work is to be conducted on the refrigeration equipment or any associated parts, appropriate fire extinguishing equipment shall be available to hand. Have a dry powder or CO₂ fire extinguisher adjacent to the charging area.
- No ignition sources. No person carrying out work in

relation to a refrigeration system which involves exposing any pipe work that contains or has contained flammable refrigerant shall use any sources of ignition in such a manner that it may lead to the risk of fire or explosion. All possible ignition sources, including cigarette smoking, should be kept sufficiently far away from the site of installation, repairing, removing and disposal, during which flammable refrigerant can possibly be released to the surrounding space. Prior to work taking place, the area around the equipment is to be surveyed to make sure that there are no flammable hazards or ignition risks. “No Smoking” signs shall be displayed.

- Ventilated area. Ensure that the area is in the open or that it is adequately ventilated before breaking into the system or conducting any hot work. A degree of ventilation shall continue during the period that the work is carried out. The ventilation should safely disperse any released refrigerant and preferably expel it externally into the atmosphere.
- Checks to the refrigeration equipment. Where electrical components are being changed, they shall be fit for the purpose and to the correct specification. At all times the manufacturer’s maintenance and service guidelines shall be followed. If in doubt consult the manufacturer’s technical department for assistance. The following checks shall be applied to installations using flammable refrigerants: the charge size is in accordance with the room size within which the refrigerant containing parts are installed; the ventilation machinery and outlets are operating adequately and are not obstructed; if an indirect refrigerating circuit is being used, the secondary circuit shall be checked for the presence of refrigerant; marking to the equipment continues to be visible and legible. Markings and signs that are illegible shall be corrected; refrigeration pipe or components are installed in a position where they are unlikely to be exposed to any substance which may corrode refrigerant containing components, unless the components are constructed of materials which are

inherently resistant to being corroded or are suitably protected against being so corroded.

- Checks to electrical devices. Repair and maintenance to electrical components shall include initial safety checks and component inspection procedures. If a fault exists that could compromise safety, then no electrical supply shall be connected to the circuit until it is satisfactorily dealt with. If the fault cannot be corrected immediately but it is necessary to continue operation, an adequate temporary solution shall be used. This shall be reported to the owner of the equipment so all parties are advised.

Initial safety checks shall include: that capacitors are discharged: this shall be done in a safe manner to avoid possibility of sparking; that there no live electrical components and wiring are exposed while charging, recovering or purging the system; that there is continuity of earth bonding.

Repairs to sealed components

- During repairs to sealed components, all electrical supplies shall be disconnected from the equipment being worked upon prior to any removal of sealed covers, etc. If it is absolutely necessary to have an electrical supply to equipment during servicing, then a permanently operating form of leak detection shall be located at the most critical point to warn of a potentially hazardous situation.
- Particular attention shall be paid to the following to ensure that by working on electrical components, the casing is not altered in such a way that the level of protection is affected. This shall include damage to cables, excessive number of connections, terminals not made to original specification, damage to seals, incorrect fitting of glands, etc. Ensure that apparatus is mounted securely. Ensure that seals or sealing materials have not degraded such that they no longer serve the purpose of preventing the ingress of flammable atmospheres. Replacement parts shall be in accordance with the manufacturer's specifications.

Note: The use of silicon sealant may inhibit the effectiveness of some types of leak detection equipment. Intrinsically safe components do not have to be isolated prior to working on them.

Repair to intrinsically safe components

Do not apply any permanent inductive or capacitance loads to the circuit without ensuring that this will not exceed the permissible voltage and current permitted for the equipment in use. Intrinsically safe components are the only types that can be worked on while live in the presence of a flammable atmosphere. The test apparatus shall be at the correct rating. Replace components only with parts specified by the manufacturer. Other parts may result in the ignition of refrigerant in the atmosphere from a leak.

Cabling

Check that cabling will not be subject to wear, corrosion, excessive pressure, vibration, sharp edges or any other adverse environmental effects. The check shall also take into account the effects of aging or continual vibration from sources such as compressors or fans.

Detection of flammable refrigerants

Under no circumstances shall potential sources of ignition be used in the searching for or detection of refrigerant leaks. A halide torch (or any other detector using a naked flame) shall not be used.

Leak detection methods

The following leak detection methods are deemed acceptable for systems containing flammable refrigerants. Electronic leak detectors shall be used to detect flammable refrigerants, but the sensitivity may not be adequate, or may need recalibration. (Detection equipment shall be calibrated in a refrigerant-free area.) Ensure that the detector is not a potential source of ignition and is suitable for the refrigerant used. Leak detection equipment shall be set at a percentage of the LFL of the refrigerant and shall be

calibrated to the refrigerant employed and the appropriate percentage of gas (25 % maximum) is confirmed. Leak detection fluids are suitable for use with most refrigerants but the use of detergents containing chlorine shall be avoided as the chlorine may react with the refrigerant and corrode the copper pipe-work. If a leak is suspected, all naked flames shall be removed/extinguished. If a leakage of refrigerant is found which requires brazing, all of the refrigerant shall be recovered from the system, or isolated (by means of shut off valves) in a part of the system remote from the leak. Oxygen free nitrogen (OFN) shall then be purged through the system both before and during the brazing process.

Removal and evacuation

When breaking into the refrigerant circuit to make repairs – or for any other purpose – conventional procedures shall be used. However, it is important that best practice is followed since flammability is a consideration. The following procedure shall be adhered to: remove refrigerant; purge the circuit with inert gas; evacuate; purge again with inert gas; open the circuit by cutting or brazing. The refrigerant charge shall be recovered into the correct recovery cylinders. The system shall be “flushed” with OFN to render the unit safe. This process may need to be repeated several times. Compressed air or oxygen shall not be used for this task. Flushing shall be achieved by breaking the vacuum in the system with OFN and continuing to fill until the working pressure is achieved, then venting to atmosphere, and finally pulling down to a vacuum. This process shall be repeated until no refrigerant is within the system. When the final OFN charge is used, the system shall be vented down to atmospheric pressure to enable work to take place. This operation is absolutely vital if brazing operations on the pipework are to take place. Ensure that the outlet for the vacuum pump is not close to any ignition sources and there is ventilation available.

Charging procedures

In addition to conventional charging procedures, the following requirements shall be followed.

- Ensure that contamination of different refrigerants does not occur when using charging equipment. Hoses or lines shall be as short as possible to minimise the amount of refrigerant contained in them.
- Cylinders shall be kept upright.
- Ensure that the refrigeration system is earthed prior to charging the system with refrigerant.
- Label the system when charging is complete (if not already).
- Extreme care shall be taken not to overfill the refrigeration system. Prior to recharging the system it shall be pressure tested with OFN. The system shall be leak tested on completion of charging but prior to commissioning. A follow up leak test shall be carried out prior to leaving the site.

Decommissioning

Before carrying out this procedure, it is essential that the technician is completely familiar with the equipment and all its detail. It is recommended good practice that all refrigerants are recovered safely. Prior to the task being carried out, an oil and refrigerant sample shall be taken in case analysis is required prior to re-use of reclaimed refrigerant. It is essential that electrical power is available before the task is commenced.

- Become familiar with the equipment and its operation.
- Isolate system electrically.
- Before attempting the procedure ensure that :mechanical handling equipment is available, if required, for handling refrigerant cylinders; all personal protective equipment is available and being used correctly; the recovery process is supervised at all times by a competent person; recovery

equipment and cylinders conform to the appropriate standards.

- Pump down refrigerant system, if possible.
- If a vacuum is not possible, make a manifold so that refrigerant can be removed from various parts of the system.
- Make sure that cylinder is situated on the scales before recovery takes place.
- Start the recovery machine and operate in accordance with manufacturer's instructions.
- Do not overfill cylinders. (No more than 80 % volume liquid charge).
- Do not exceed the maximum working pressure of the cylinder, even temporarily.
- When the cylinders have been filled correctly and the process completed, make sure that the cylinders and the equipment are removed from site promptly and all isolation valves on the equipment are closed off.
- Recovered refrigerant shall not be charged into another refrigeration system unless it has been cleaned and checked.

Labelling

Equipment shall be labelled stating that it has been de-commissioned and emptied of refrigerant. The label shall be dated and signed. Ensure that there are labels on the equipment stating the equipment contains flammable refrigerant.

Recovery

When removing refrigerant from a system, either for servicing or decommissioning, it is recommended good practice that all refrigerants are removed safely. When transferring refrigerant into cylinders, ensure that only

appropriate refrigerant recovery cylinders are employed. Ensure that the correct number of cylinders for holding the total system charge are available. All cylinders to be used are designated for the recovered refrigerant and labelled for that refrigerant (i.e. special cylinders for the recovery of refrigerant). Cylinders shall be complete with pressure relief valve and associated shut-off valves in good working order. Empty recovery cylinders are evacuated and, if possible, cooled before recovery occurs.

The recovery equipment shall be in good working order with a set of instructions concerning the equipment that is at hand and shall be suitable for the recovery of flammable refrigerants. In addition, a set of calibrated weighing scales shall be available and in good working order. Hoses shall be complete with leak-free disconnect couplings and in good condition. Before using the recovery machine, check that it is in satisfactory working order, has been properly maintained and that any associated electrical components are sealed to prevent ignition in the event of a refrigerant release. Consult manufacturer if in doubt. The recovered refrigerant shall be returned to the refrigerant supplier in the correct recovery cylinder, and the relevant Waste Transfer Note arranged. Do not mix refrigerants in recovery units and especially not in cylinders.

If compressors or compressor oils are to be removed, ensure that they have been evacuated to an acceptable level to make certain that flammable refrigerant does not remain within the lubricant. The evacuation process shall be carried out prior to returning the compressor to the suppliers. Only electric heating to the compressor body shall be employed to accelerate this process. When oil is drained from a system, it shall be carried out safely.

Competence of service personnel

- General:

Special training additional to usual refrigerating equipment repair procedures is required when equipment with flammable refrigerants is affected. In many countries, this

training is carried out by national training organisations that are accredited to teach the relevant national competency standards that may be set in legislation. The achieved competence should be documented by a certificate.

- Training:

The training should include the substance of the following:
Information about the explosion potential of flammable refrigerants to show that flammables may be dangerous when handled without care.

Information about potential ignition sources, especially those that are not obvious, such as lighters, light switches, vacuum cleaners, electric heaters.

Information about the different safety concepts:

Unventilated – (see Clause GG.2) Safety of the appliance does not depend on ventilation of the housing. Switching off the appliance or opening of the housing has no significant effect on the safety. Nevertheless, it is possible that leaking refrigerant may accumulate inside the enclosure and flammable atmosphere will be released when the enclosure is opened.

Ventilated enclosure – (see Clause GG.4) Safety of the appliance depends on ventilation of the housing. Switching off the appliance or opening of the enclosure has a significant effect on the safety. Care should be taken to ensure a sufficient ventilation before.

Ventilated room – (see Clause GG.5) Safety of the appliance depends on the ventilation of the room. Switching off the appliance or opening of the housing has no significant effect on the safety. The ventilation of the room shall not be switched off during repair procedures.

Information about the concept of sealed components and sealed enclosures according to IEC 60079-15:2010.

Information about the correct working procedures:

a) Commissioning

- Ensure that the floor area is sufficient for the refrigerant

charge or that the ventilation duct is assembled in a correct manner.

- Connect the pipes and carry out a leak test before charging with refrigerant.
- Check safety equipment before putting into service.

b) Maintenance

- Portable equipment shall be repaired outside or in a workshop specially equipped for servicing units with flammable refrigerants.
- Ensure sufficient ventilation at the repair place.
- Be aware that malfunction of the equipment may be caused by refrigerant loss and a refrigerant leak is possible.
- Discharge capacitors in a way that won't cause any spark. The standard procedure to short circuit the capacitor terminals usually creates sparks.
- Reassemble sealed enclosures accurately. If seals are worn, replace them.
- Check safety equipment before putting into service.

c) Repair

- Portable equipment shall be repaired outside or in a workshop specially equipped for servicing units with flammable refrigerants.
- Ensure sufficient ventilation at the repair place.
- Be aware that malfunction of the equipment may be caused by refrigerant loss and a refrigerant leak is possible.
- Discharge capacitors in a way that won't cause any spark.
- When brazing is required, the following procedures shall be carried out in the right order:
 1. Remove the refrigerant. If the recovery is not required by national regulations, drain the refrigerant to the outside. Take care that the drained refrigerant will not cause any danger. In doubt, one person should guard the outlet. Take special care that drained refrigerant will not float back into the building.
 2. Evacuate the refrigerant circuit.
 3. Purge the refrigerant circuit with nitrogen for 5 min.

4. Evacuate again.
5. Remove parts to be replaced by cutting, not by flame.
6. Purge the braze point with nitrogen during the brazing procedure.
7. Carry out a leak test before charging with refrigerant.

Reassemble sealed enclosures accurately. If seals are worn, replace them.

Check safety equipment before putting into service.

d) Decommissioning

- If the safety is affected when the equipment is putted out of service, the refrigerant charge shall be removed before decommissioning.
- Ensure sufficient ventilation at the equipment location.
- Be aware that malfunction of the equipment may be caused by refrigerant loss and a refrigerant leak is possible.
- Discharge capacitors in a way that won't cause any spark.
- Remove the refrigerant. If the recovery is not required by national regulations, drain the refrigerant to the outside. Take care that the drained refrigerant will not cause any danger. In doubt, one person should guard the outlet. Take special care that drained refrigerant will not float back into the building.
- Evacuate the refrigerant circuit.
- Purge the refrigerant circuit with nitrogen for 5 min.
- Evacuate again.
- Fill with nitrogen up to atmospheric pressure.
- Put a label on the equipment that the refrigerant is removed.

e) Disposal

- Ensure sufficient ventilation at the working place.
- Remove the refrigerant. If the recovery is not required by national regulations, drain the refrigerant to the outside. Take care that the drained refrigerant will not cause any danger. In doubt, one person should guard the outlet. Take special care that drained refrigerant will not float back into the building.
- Evacuate the refrigerant circuit.

- Purge the refrigerant circuit with nitrogen for 5 min.
- Evacuate again.
- Cut out the compressor and drain the oil.

Transportation, marking and storage for units that employ flammable refrigerants

- Transport of equipment containing flammable refrigerants:

Attention is drawn to the fact that additional transportation regulations may exist with respect to equipment containing flammable gas. The maximum number of pieces of equipment or the configuration of the equipment, permitted to be transported together will be determined by the applicable transport regulations.

- Marking of equipment using signs:

Signs for similar appliances used in a work area generally are addressed by local regulations and give the minimum requirements for the provision of safety and/or health signs for a work location.

All required signs are to be maintained and employers should ensure that employees receive suitable and sufficient instruction and training on the meaning of appropriate safety signs and the actions that need to be taken in connection with these signs.

The effectiveness of signs should not be diminished by too many signs being placed together.

Any pictograms used should be as simple as possible and contain only essential details.

- Disposal of equipment using flammable refrigerants:

See national regulations.

- Storage of equipment/appliances:

The storage of equipment should be in accordance with the manufacturer's instructions.

Storage package protection should be constructed such that mechanical damage to the equipment inside the package will not cause a leak of the refrigerant charge. The

maximum number of pieces of equipment permitted to be stored together will be determined by local regulations.

Maximum refrigerant charge amount

Model	Refrigerant amount (g)
EDH12TRBD2	65
EDH14TRBD2	110



"The software in this product contains components that are based on free and open source software. Electrolux gratefully acknowledges the contributions of the open software and robotics communities to the development project. To access the source code of these free and open source software components whose license conditions require publishing, and to see their full copyright information and applicable license terms, please visit: <http://electrolux.opensoftwarerepository.com> (folder NIU5)"

2. PRODUCT DESCRIPTION

2.1 General overview

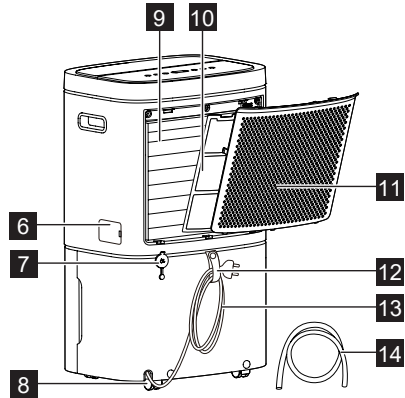
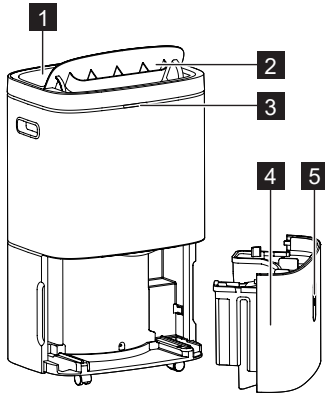

- 1** Control panel
- 2** Louvre / Air outlet
- 3** Air Quality Index (AQI) indicator
- 4** Water tank
- 5** Water level indication
- 6** Air quality sensor
- 7** Drainage plug / Water outlet

- 8** Castors
- 9** High efficiency particle filter
- 10** Mesh pre-filter
- 11** Filter lid / Air intake
- 12** Wire Tag
- 13** Power cord
- 14** Drainage hose



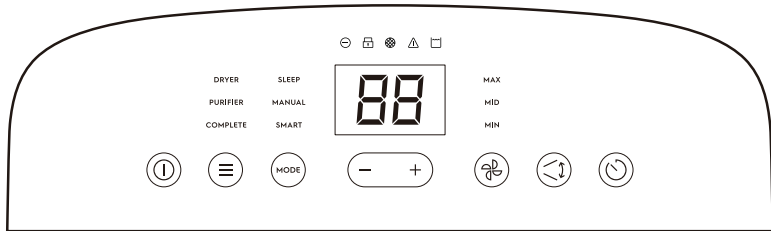



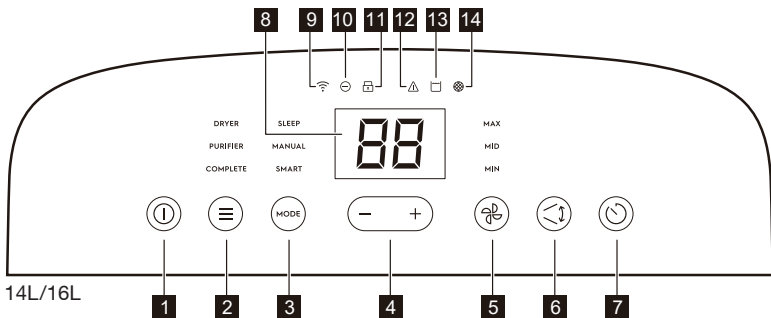





2.2 Control panel layout



12L (Without Connectivity)



14L/16L

Number	Symbol	Buttons	Description
1		ON/OFF button	To power ON and OFF the appliance. To activate the appliance hotspot for Connectivity by long press. Connectivity on select models only.
2		Function button	To switch between the function settings: <ul style="list-style-type: none"> • Dryer • Purifier • Complete
3	MODE	Mode button	To switch between the modes selection: <ul style="list-style-type: none"> • Sleep • Manual • Smart
4	- / +	Minus / Plus button	To adjust the timer and humidity setting.
5		Fan speed button	To set the fan speed in Manual mode. You can switch between 3 speeds: <ul style="list-style-type: none"> • MAX • MID • MIN
6		Swing mode button	To swing the louvre up and down and direct the air flow.
7		Timer button	To set the switch-on and switch-off time.
8		Digital display	To show the humidity level, timer setting and error codes.
Indicators			
9		Wi-Fi (select models)	To show the status of the appliance's connectivity feature, whether it is active or inactive. Connectivity on select models only.
10		Ionizer	To show that the function is active.
11		Child lock	To show that the function is active.
12		Alert	To show that an error occurred.
13		Water tank full	To remind you that the water tank is full and to empty the water tank. To remind you that the water tank has not been installed correctly.
14		Filter change	To remind you to replace the high efficiency particle filter.



See section "4. OPERATING INSTRUCTIONS" for the descriptions in detail.

3. BEFORE FIRST USE

3.1 Selecting a Location

Important

1. Appliance must be upright for one hour prior to operating.
2. Place the appliance in a location with minimum 20cm distance around the unit (at least 40cm of air space on air outlet).
3. A dehumidifier operating in a storage room will have little or no effect in drying enclosed areas such as closets etc, unless there is adequate circulation of air in and out of the area.
4. The appliance must be installed on a level floor that can support it even with a full tank of water.
5. The presence of water in the water tank during first use is normal.

3.2 How It Works

1. The unit is designed to operate between 5°C (41°F) and 35°C (96°F). The unit will not work properly if the temperature is out of this temperature range, or the performance of the unit decreases greatly.
2. The compressor circuit has an automatic 3-minute time delayed start if the unit is turned off and on quickly. This prevents overheating of the compressor and possible circuit breaker tripping.
3. If the appliance is unplugged or the electricity has been cut off when the unit is operating, the unit will set back to previous setting after the power is on again.

3.3 Connectivity / Wi-Fi / App

For selected models only: This feature allows you to connect your appliance to the internet and link it to the App on your smartphone. By this functionality you can receive notifications, control and monitor your appliance from your smart phone. To connect your appliance to the internet via the App, you need a wireless network

at home with internet connection (Wi-Fi) and an Android or iOS smart phone.

NOTE:

Connect your unit to the 2,4 GHz band on your wireless (Wi-Fi) router when onboarding instead of the 5 GHz band. This will give a stronger and longer range signal.

Please follow the steps below to connect your appliance to the internet (onboard the unit):

1. Download the app to your mobile device from Google Play (Android) or App Store (iOS).
2. Open the app and register to create an account.
3. Select your Dehumidifier from the list.
4. Plug the appliance into the power socket.
5. Follow the instructions in the app to complete the onboarding process.

If you are unable to successfully connect your appliance to the internet, consult the troubleshoot guide in section "6. What to do if...".

3.4 Remove the plastic protective bag from the high efficiency particle filter packaging

If your product comes with high efficiency particle filter, please remove the protective plastic packaging covering the filter before first use of appliance.

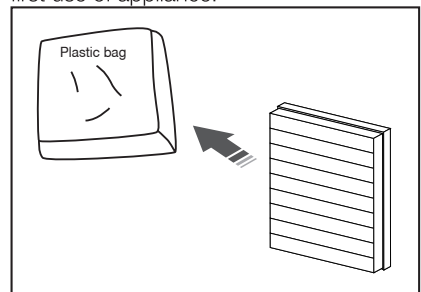

See section "4.12 Filter Change Indicator" for the high efficiency particle filter installation/replacement instructions in detail.

4. OPERATING INSTRUCTIONS

4.1 To Turn On the appliance

To begin operating the dehumidifier, make sure the appliance is plugged in correctly.

Once plugged, the appliance is on standby status. The indicators on the control panel are dimmed except "ⓘ" and "☾".

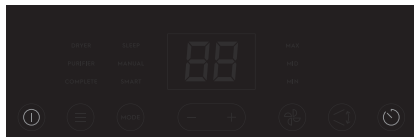

1. Tap (touch and release) "ⓘ" to turn on the appliance. The display shows the current room humidity. The COMPLETE function and SMART mode are activated by default in the first use.

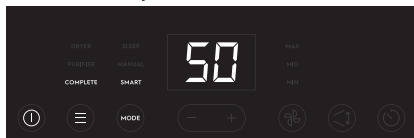

2. In active state, tap "ⓘ" to turn off the appliance. The appliance stops operating and switches to standby.

4.2 Discreet state

If user does not interact with the control panel for over 60 seconds, the control panel will enter inactive state where "ⓘ", "☰", and "MODE" buttons are dimmed to 30% and the other text, icons and display screen will be dimmed to 0% (not visible).

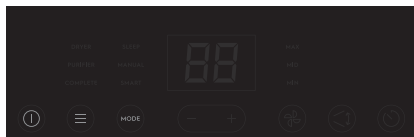

NOTE:

- In inactive state, the appliance will keep operating according to your last setting.
- Tap any button on the control panel to 'wake up' the display, then press again to change setting. Tapping only once, when control panel is in discreet state, will not change any settings or turn off the appliance.

4.3 Basic function selection

Tap "☰" button to choose your desired basic function between COMPLETE function, DRYER function and PURIFIER function.

Complete function

In this function, the appliance purifies and dehumidifies the air at the same time, decreasing the humidity and maintaining comfortable air quality, SMART mode is activated by default in the first use.

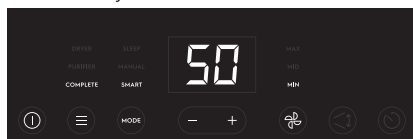

Purifier function

In this function, the appliance purifies the air and maintains air quality at a healthy level.

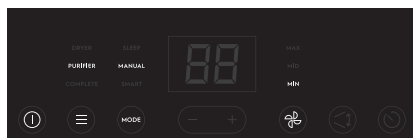

NOTE:

- In the PURIFIER function, the appliance does not dehumidify the air as the compressor is turned off, only the fan is working.
- In the PURIFIER function, the display screen is turned off. Please refer to section "4.11 Air Quality Index (AQI) Indicator" to know more about how to assess air quality level.

Dryer function

In this function, the appliance operates at the highest capacity and fan speed, with louvre swinging to the maximum angle to quickly decrease excess humidity found in the room. You can use this function in a scenario such as line drying of laundry.

**NOTE:**

- In DRYER function, the appliance operates at MAX fan speed by default, you can also adjust the fan speed as you want. User cannot set target humidity setting while in this function.
- The DRYER function operates for up to 8 hours if unattended, after that time the appliance will turn off automatically.
- The appliance will stop operating if the water tank is full before reach 8 hours. Please empty the water tank to restart the operation.

WARNING!

- Do not cover the air outlet of the appliance with clothes. It may cause excessive heat, fire or failure of unit.
- Do not place the wet clothes on the top of the appliance and do not make the water drop into the unit. It may cause electric shock, creepage or failure of unit.

4.4 Mode selection

If you have chosen COMPLETE or PURIFIER function, tap "MODE" button to choose your desired mode between SMART mode, MANUAL mode and SLEEP mode.

NOTE:

- The MODE button is disabled when DRYER function is selected.

Smart mode

1. When choosing COMPLETE function + SMART mode - the appliance aims to main both the humidity and air quality at a comfortable and healthy level. The appliance will automatically adjust fan speed based on a combination of both these factors.

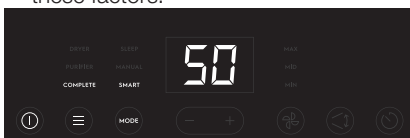

2. When choosing PURIFIER function + SMART mode - the appliance aims to maintain the best indoor air quality (it does not dehumidify). The appliance will automatically adjust fan speed based on input from the PM sensor. Display screen on control panel is turned off.

**NOTE:**

- In SMART mode, you cannot adjust the humidity setting and the fan speed.

Manual mode

1. When choosing COMPLETE function, in MANUAL mode, tap "—" and "+" button to set target humidity in 5% increments between 35%-85% and tap "fan speed" button to change the fan speed to MIN, MID, MAX.

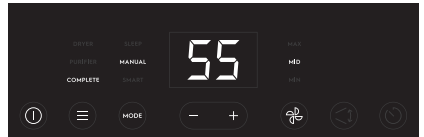
**NOTE:**

- Once desired target humidity is selected, the display screen will shift back to showing 'current' real-time room humidity level.
2. When choosing PURIFIER function + MANUAL mode, you can tap "fan speed" button to change the fan speed to MIN, MID, MAX.

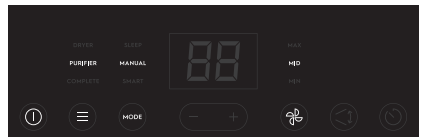

Sleep Mode

1. SLEEP mode is designed to be non-disturbing. When selected, it will aim to provide a low noise environment (as available) with lowest fan speed setting, dim display and turn off the Air Quality Indicator light.



2. PURIFIER function + SLEEP mode will have lower noise than COMPLETE + SLEEP, as the dehumidification function is turned off.

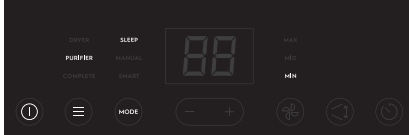

NOTE:

- In SLEEP mode, cannot set the target humidity and the fan speed.
- In SLEEP mode, after 10 seconds without any interaction with the control panel, the "1", "≡" and "MODE" buttons are dimmed to 30% and the other text, icons will be turned off completely to be non-disturbing.

4.5 To Run in Continuous Operation

1. Choose COMPLETE function + MANUAL mode, then tap the "-" button to reduce target humidity setting below 35% till the display shows "CO" and the appliance enters Continuous operation.

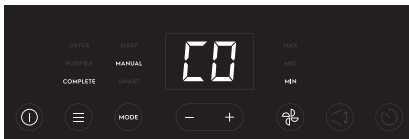

2. To exit Continuous Operation (CO) function, tap the "≡" or "MODE" button. You can also adjust the target humidity setting above 35% to exit this function.

NOTE:

- It is recommended to connect the drainage hose to dehumidifier when using in Continuous operation, to prevent the operation from stopping when the water tank is full frequently.

4.6 Swing

The air outlet in the appliance has an in-built louvre. You can turn on this feature, for the louvre to automatically move up & down continuously so as to better direct the air flow.

1. Tap "$\swarrow\searrow$" button to enable the auto swing feature, the louvre will swing up and down automatically.

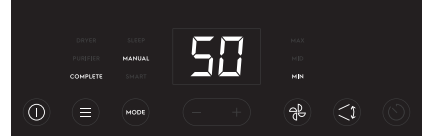

2. Tap the button again to stop the louvre at your desired angle/direction.

NOTE:

- Please do not adjust the position of louvre manually.
- Please ensure louvre is NOT stopped at completely closed position when deactivating SWING feature and appliance still operating, as this cause overheating.

4.7 Timer

The TIMER feature allows you to have either Delayed Start OR Delayed Stop for the appliance, in increments of 0.5 to 1 hours (up-to the max of 12 hours).

1. When the appliance is on, tap "\odot" button and display should change to "0.0" to reflect Delayed Stop is initiated. Tap or hold "-" and "+" button to change the time by 0.5 hour increments, up to 6 hours, then at 1 hour increments up to 12 hours. The appliance will count down the time remaining, until appliance switches OFF by itself.

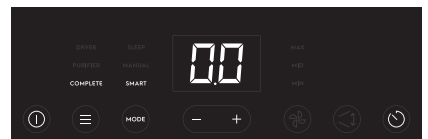

2. When the appliance is off, tap "\odot" button and display should change to "0.0" to reflect Delayed Start is initiated. Tap or hold "-" and "+" button to change the timer setting as mentioned above. The appliance will count down

the time remaining, until appliance switches ON by itself.

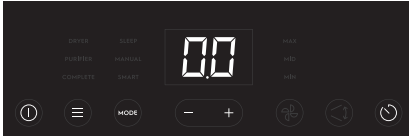

- The selected time will be set as target (registered) when user does not interact with control panel for 5 seconds after choosing desired time. Once time is set, display screen will revert back to show room humidity levels, tap "⏸" button once, display screen will show the remain time.
- To exit & cancel the timer feature, tap "⏸" button twice OR turn the unit ON/OFF by pressing the power button anytime OR adjust the timer setting to "0.0" hours.

NOTE:

- Before entering TIMER setting, make sure power is being supplied to the appliance.
- Before entering Delayed Start, make sure you have chosen your desired setting, for example, if you want the appliance turn on and operate with COMPLETE function + MANUAL mode + 50% humidity + MAX fan speed after 5 hours automatically, tap "☰", "MODE", "—" or "+" and "⌚" sequentially to set your desired setting and turn off the appliance, then follow step 2 to initiate the Delayed Start time to 5 hours.

4.8 Ionizer Indicator

Long press "☰" and "MODE" buttons simultaneously for 5 seconds to activate/inactivate the ionizer feature. When the ionizer feature is activated, the "⊖" indicator will show on the control panel and the ionizer is energized to help to clean the air. This function is recommended when the indoor air quality is in bad condition.

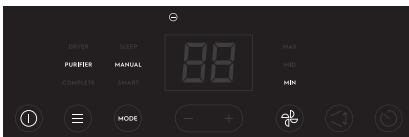

4.9 Child Lock Indicator

Long press "⓪" and "MODE" buttons simultaneously for 5 seconds to activate/inactivate the Child Lock feature. When the Child Lock feature is activated, the "🔒" indicator will show on the control panel and the control panel is locked.

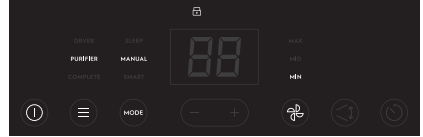

4.10 Water Tank Full Indicator

When the water tank is full, the indicator "🔊" lights up and the unit will make a double short beeps and repeat the sounds after first double beeps to remind you to empty the water tank. The compressor will stop immediately and the fan will still keep running. See section "4.15 Use the Water Tank" to know how to handle and empty the water tank.

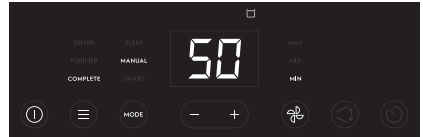

NOTE:

- In SLEEP mode, no beep sound reminder when the Water Tank is full.

4.11 Air Quality Index (AQI) Indicator

The appliance has an air quality sensor that analyses the air quality index. The AQI (air quality index) light will show the real-time air quality through different colours of light as shown below:

AQI INDICATOR COLOR	PM 2.5 (µg/m³)	AIR QUALITY LEVEL
Blue	0-15	Very Good
Green	16-35	Good
Orange	36-75	Bad
Red	>75	Very Bad

4.12 Filter Change Indicator

The filter change icon "⊗" will light up to remind you to replace the high efficiency particle filter (Ref.# EFCAREU7). Refer to the Electrolux Life App or the Electrolux website on where to purchase replacement filters. Always ensure the plastic protective packaging is removed from the filter before its use in the unit.

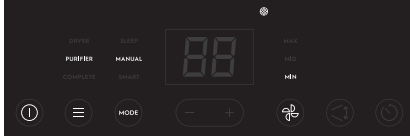

NOTE:

- The high efficiency particle filter cannot be washed, it can only be replaced.
- if change to another model of filter, please follow the replacement frequency according to the instruction for the new filter.

Follow below steps on how to replace your high efficiency particle filter:

1. Open the filter lid with the finger pull from the top.

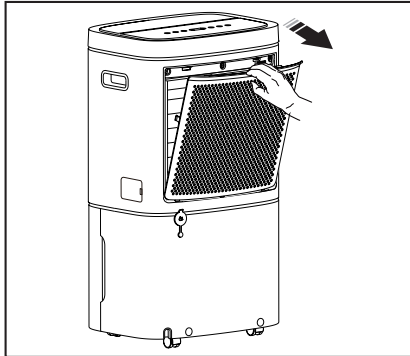

2. Take out the high efficiency particle filter.

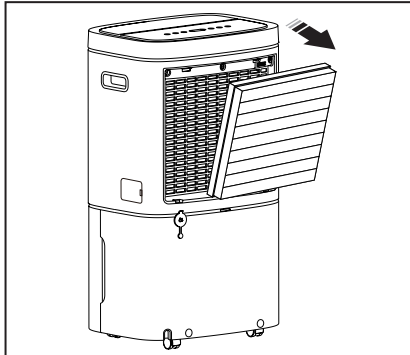

3. Replace the new filter into the unit (blue side outwards) and close the filter lid.

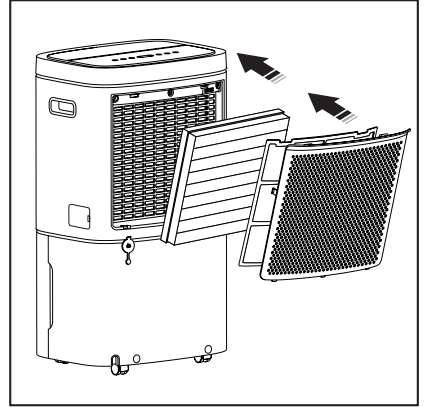

4. Reset the filter change indicator, press and hold the "⓪" and "☰" buttons for 5 seconds to reset the indicator.

4.13 Connectivity (Wi-Fi) Feature

For selected models only: The appliance is equipped with a Wi-Fi chip that enables it to be connected to the internet and via the App enables you to control and access its full functionality remotely. Download our Electrolux Life App and follow the instructions for how to connect your appliance to the internet. When the connection is established, the "📶" indicator will light up.

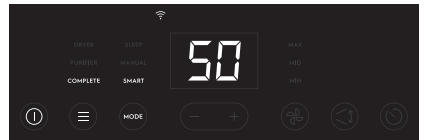

Please refer to the 'Quick Start Guide' or the instructions in the App for details on how to connect your appliance to the internet.

4.14 Alerts & Errors

When a problem occurs in the appliance, the "⚠" indicator will show on the control panel and the display will show the corresponding error code at the same time.

- E3-** PM2.5 sensor failure
- E4-** DC Motor failure
- E5-** Humidity sensor failure
- E6-** Communication Failure
- E7-** Indoor defrost thermistor failure.
- E8-** Refrigerant Leakage



NOTE:

- For error code E3, appliance will continue to run (some features may be disabled), but for the other error codes, it will stop operation completely.
- When error code occurred, unplug the unit and plug it back in. If error repeats, please contact Authorised Service Centre.

4.15 Removing collected water

There are two ways to remove collected water.

Use the Water Tank

When the water tank is full, the Water Tank Full indicator "☑" will flash and the unit will make a double short beeps and repeat the sounds after first double beeps to remind you to empty the water tank.

Following the steps below to remove the collected water from the water tank:

1. Grip the water tank edges of the grooves on both sides securely, then pull out the water tank a little.

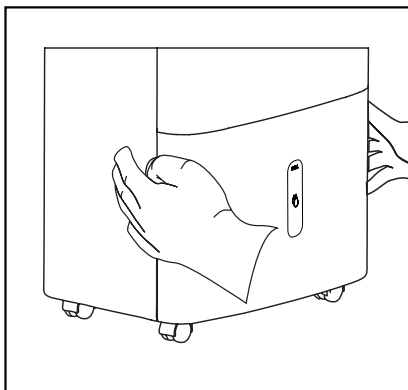

2. Hold both sides of the water tank with even strength, and pull it out from the unit.

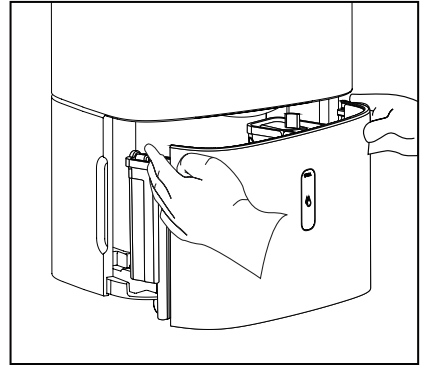

3. Grip the water tank handle and open the water tank sealing cap in the side corner, then empty the water tank.

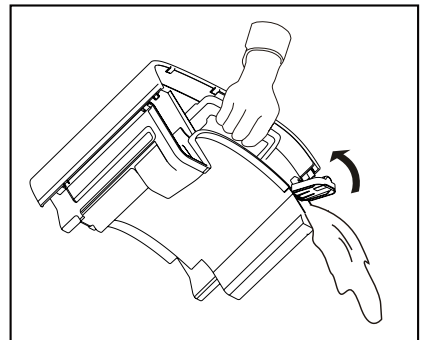
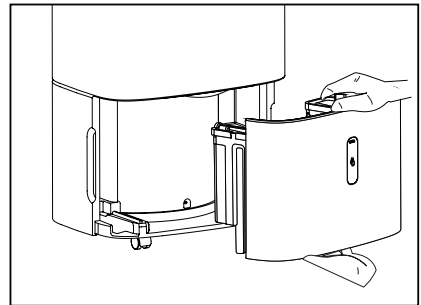

4. Close the sealing cap and put back the water tank in place.

The water tank full indicator will turn off, and the unit will start up again when the water tank is restored in its correct position.

NOTE:

- When you remove the water tank, do not touch any parts inside the unit, otherwise the product may be damaged.
- Be sure to push the water tank gently all the way into the unit. Banging the water tank against anything or failing to push it in place may cause the unit not to operate.
- Because the castors cannot be locked, you need to apply a limited force so that appliance does not move suddenly.
- Discard water from water tank. The water in the water tank is not potable.

Continuous Drainage

Once the continuous drainage is enabled, water can be automatically emptied from the appliance and the water will not flow into the water tank unless there is something wrong with the continuous drainage. You will need a drainage hose and a drain nearby to discharge the water into before conducting this operation. Following the steps below to make sure the hose to be connected correctly:

1. Pull down the drainage plug at the back of the unit.

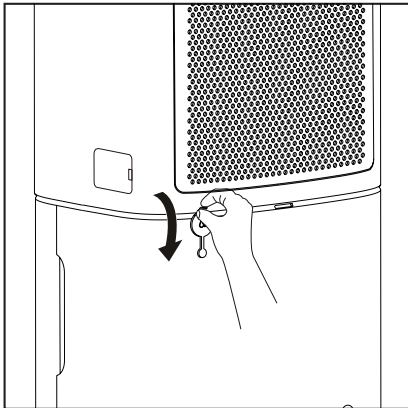

2. Push the drainage hose firmly into the drainage outlet to make sure the hose to be connected to the unit properly so there will be no leaks.

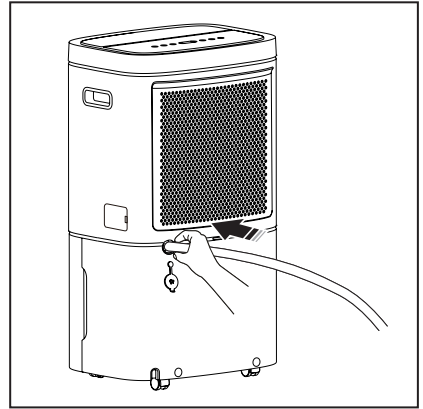

3. Direct the hose toward the drain and place the other end of the hose into the drain, making sure that there are no kinks that will stop the water from flowing smoothly.

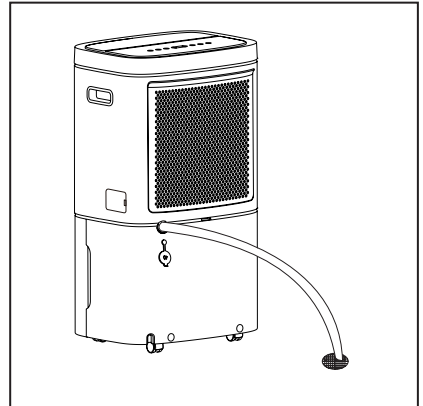

4. Select the desired humidity setting and fan speed on the unit for continuous draining to start.

NOTE:

- Make sure the water tank has been installed properly before trying to connect the drainage hose to the drainage outlet.
- Shake or pull the hose slightly to make sure the hose is connected properly. If there is a leak, pull out the hose and repeat the above-mentioned hose connection process.
- It is recommended that a Dehumidifier Drain Hose - (12 mm) be used. Make sure there are no kinks or elevations in the hose.

5. CARE, CLEANING AND STORAGE

5.1 To Clean the appliance

WARNING!

Before cleaning the unit, make sure to disconnect the unit from power supply.

1. Clean the Filter lid and Case

- The plastic surface of the appliance may be cleaned with an oil-free dry cloth or a vacuum cleaner equipped with a soft brush.

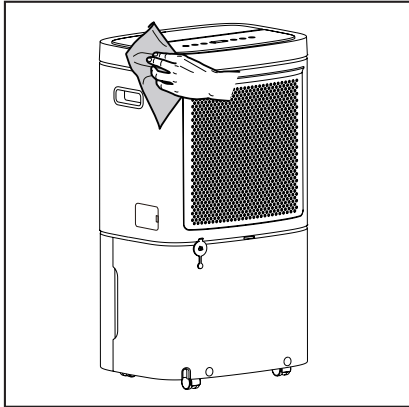

- Use the slightly damp cloth. Do not use bleach or abrasives.
- Do not splash water directly onto the unit. Doing so may cause electric shock, insulation failure, or rusting.
- The air intake grille and outlet get soiled easily, so cleaning such parts with a vacuum cleaner is recommended.

2. Clean the Water Tank

Every 4-6 weeks, clean the water tank to prevent growth of mold, mildew and bacteria.

- a. Pull out the water tank from the unit.
- b. Take off the handle following the steps as shown in below image.

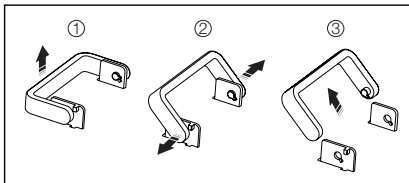

- c. Open the cover lid of the water tank.

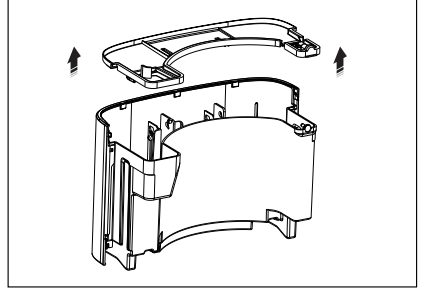

- d. Partially fill the water tank with clean water and add a little mild detergent. Swish it around, then empty and rinse the water tank.
- e. Reinstall the cover lid, handle and put the water tank back into the unit.

NOTE:

- Do not use a dishwasher to clean the water tank. After cleaning, the water tank must be put back in place so the appliance will operate properly.

3. Clean the Air Quality Sensor

Dust accumulated in the air quality sensor may result in incorrect sensor readings and affect performance. Use a vacuum cleaner with a soft brush to remove dust that might accumulate in this area. Vacuum at least once every 4 weeks or as per instructions in the Electrolux Life App.

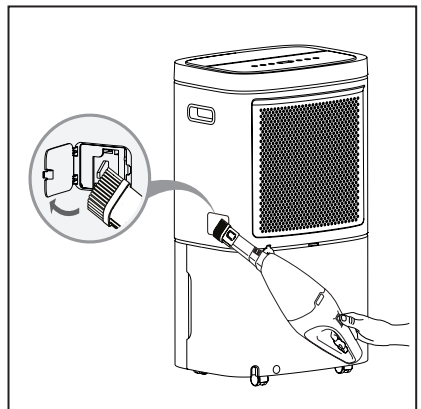

4. Clean the Mesh Pre-filter

The mesh pre-filter is put together with the filter lid at the back of the appliance, it should be checked and cleaned at least every 30 days or more often if necessary.

NOTE: DO NOT PUT THE FILTER IN A DISHWASHER.

- a. Open the filter lid and you will find the mesh pre-filter is put behind the back of the lid.

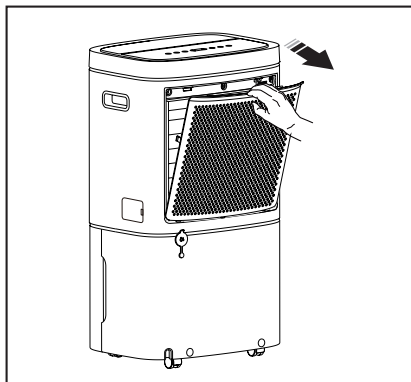

- b. Take out the mesh pre-filter from the assembly.

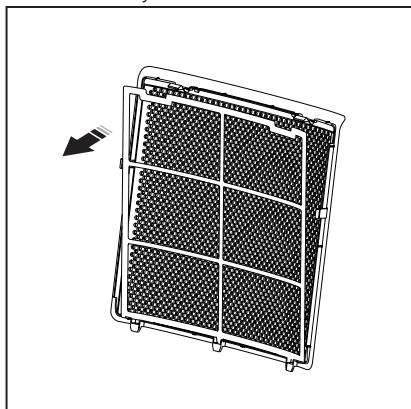

- c. Clean the mesh pre-filter with warm, soapy water. Rinse and dry it by airing before putting it back.
- d. Reinstall the filter, then put the filter lid back.

! CAUTION!

DO NOT operate the appliance without a filter because dirt and lint will clog inside the appliance, which will affect the performance..

5.2 Replace the high efficiency particle filter

See section "4.12 Filter Change Indicator" for the details when and how to replace the high efficiency particle filter.

NOTE:

- Be different from the mesh pre-filter, the high efficiency particle filter can not be washed, it can only be replaced.

Please visit electrolux.com to order your replacement filter.

 electrolux.com

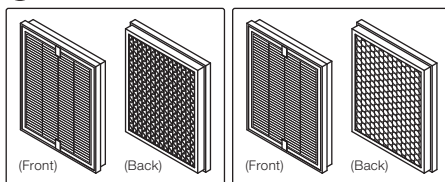

Care Ultimate Protect Filter

Ref: EFCAREU7
PNC: 900923460

FRESH Active Carbon Filter

Ref: EFCAREFU7
PNC: 900923696

5.3 Storage

If you are not going to use the appliance for a long time, please store it properly.

1. Unplug the appliance, then tidy up the power cord using the tag at the back of the unit.

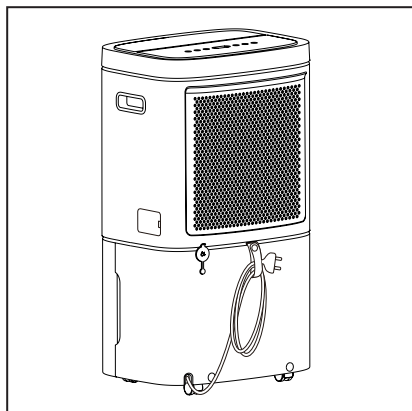

2. Empty the water tank and clean the mesh pre-filter.
3. Dry the appliance and all accessories by airing.
4. Pack it with plastic bag or return it to its carton then place the unit in a cool and dry place.

6. WHAT TO DO IF...

Before calling for service, review this list. It may save you time and expense. This list includes common occurrences that are not the result of defective workmanship or materials in this appliance.

Occurrence	Possible Cause	Solution
Dehumidifier does not operate	Wall plug disconnected.	Push plug firmly into wall outlet.
	House fuse blown or circuit breaker tripped.	Replace fuse with time delay type or reset circuit breaker.
	The dryness level you selected has been reached.	Dehumidifier automatically shuts off when selected amount of moisture has been removed from the air. If you want to remove more moisture, enter in Continuous operation. After the dehumidifier starts, reset the control panel to the desired setting.
	Water Tank not installed properly.	See "4.15 Removing Collected Water".
	Water in the water tank has reached its preset level.	Dehumidifier automatically turns off when this occurs. Empty water tank and return it to position.
	Dehumidifier is not turned on.	Turn unit on.
The programme / cycle lasts too long.	Windows or doors near dehumidifier are open to outdoors.	Close all windows or doors to outside.
	Area to be dehumidified is too large.	Check with your dealer to see if capacity is adequate.
	Air movement through dehumidifier is blocked. Grill may be dirty.	Use brush attachment of vacuum cleaner to clean grill. See "5. Care, Cleaning and Storage". Dehumidifier must be placed in a space that does not restrict air flowing into the air intake or outlet.
	Dehumidifier has been installed or restarted recently.	The higher the moisture in the room, the longer the dehumidifier will operate.
	Dehumidifier is in the Continuous operation and will remain on in this mode.	Exit this operation.

Occurrence	Possible Cause	Solution
Dehumidifier is operating, but room is not dry enough.	Humidity setting is too high.	Select Complete function, and adjust in manual mode to a lower setting or choose Continuous operation for maximum dryness.
	Dehumidifier has been installed or restarted recently.	The higher the moisture in the room air, the longer it takes for the room air to become dry.
	Dehumidifier does not have sufficient clearance to operate.	Air flow to air intake is blocked. See "3.1 Selecting a Location" .
	Room temperature is too low.	Unit will not operate satisfactorily if the room temperature is below 5°C (41°F). See "3.2 How it Works" .
	Refer to causes under "The programme / cycle lasts too long".	
Frost appears on coils above water tank.	Dehumidifier has been turned on recently.	This is normal due to refrigerant rushing through the coil. Frost will usually disappear within 60 minutes.
Abnormal noise.	Room Temperature is too low.	Please operate dehumidifier when room temperature is above 5°C (41°F).
	The floor is not flat.	Please install the dehumidifier on level floor.
	User didn't remove high efficiency particle filter's plastic bag.	Please remove high efficiency particle filter's plastic bag.
"dF" code shows on the display, the compressor stop running and the dehumidifier works at MAX fan speed.	Room Temperature is low, the dehumidifier enters in Defrost function automatically.	This is normal, the dehumidifier will automatically quit Defrost function after some minutes and continue working with current operating setting.

Occurrence	Possible Cause	Solution
The appliance is not connected to the internet / the Wi-Fi indicator is constantly blinking. (Selected models only)	The wireless (Wi-Fi) router is not working.	Check that the router is ON and if other connected devices are working. If the router was OFF, turn it ON and wait for a few minutes and check again.
	The router needs a restart.	Try to restart the router by unplugging and plugging the router. Wait a few minutes and check again.
	Your dehumidifier is out of range from the router.	Try moving the unit closer to the router. Make sure your unit is within 10 meters range from your router and with not too many walls in between.
		Connect your unit to the 2,4 GHz band on your wireless (Wi-Fi) router when onboarding instead of the 5 GHz band. This will give a stronger and longer range signal.

7. ENVIRONMENT CONCERNS

Recycle the materials with the symbol . Put the packaging in applicable containers to recycle it. Help protect the environment and human health and to recycle waste of electrical and electronic appliances.

Do not dispose appliances marked with the symbol  with the household waste. Return the product to your local recycling facility or contact your municipal office.

www.electrolux.com/shop



CE

